



Asia-Pacific Economic Cooperation

Energy Smart Communities Initiative (ESCI)

*Progress Report to Knowledge Sharing Platform and
APEC Energy Working Group
October 2011*



ENERGY SMART COMMUNITIES INITIATIVE (ESCI)

- **Origin:** U.S. President Barack Obama and Japanese Prime Minister Naoto Kan announce ESCI in conjunction with the APEC Economic Leaders' Meeting in Yokohama in November 2010.
 - **Goal:** ESCI aims to foster green growth, sustainable development and long-term job creation throughout the Asia-Pacific by demonstrating the practicality of clean energy technologies to reduce energy intensity and increase energy security
 - **Method:** Projects will focus on research, development and demonstration of new technologies, and on dissemination and sharing of best practices for deploying the technologies already available.
-

ESCI'S FOUR PILLARS



Smart Transport



Smart Buildings



Smart Grids



Smart Jobs



Smart Communities



SMART TRANSPORT



Energy-Efficient Urban Transport Network

Energy-Efficient Freight Transport Network



Electromobility Survey and Road Map

Electric Vehicle Demonstrations



Smart Transport



SMART TRANSPORT

- Transportation accounts for 27% of final energy consumption in APEC economies.
- Smart Transport means reducing travel times, costs, energy use, and GHG emissions.

Transportation's Share of Total Final Energy Consumed

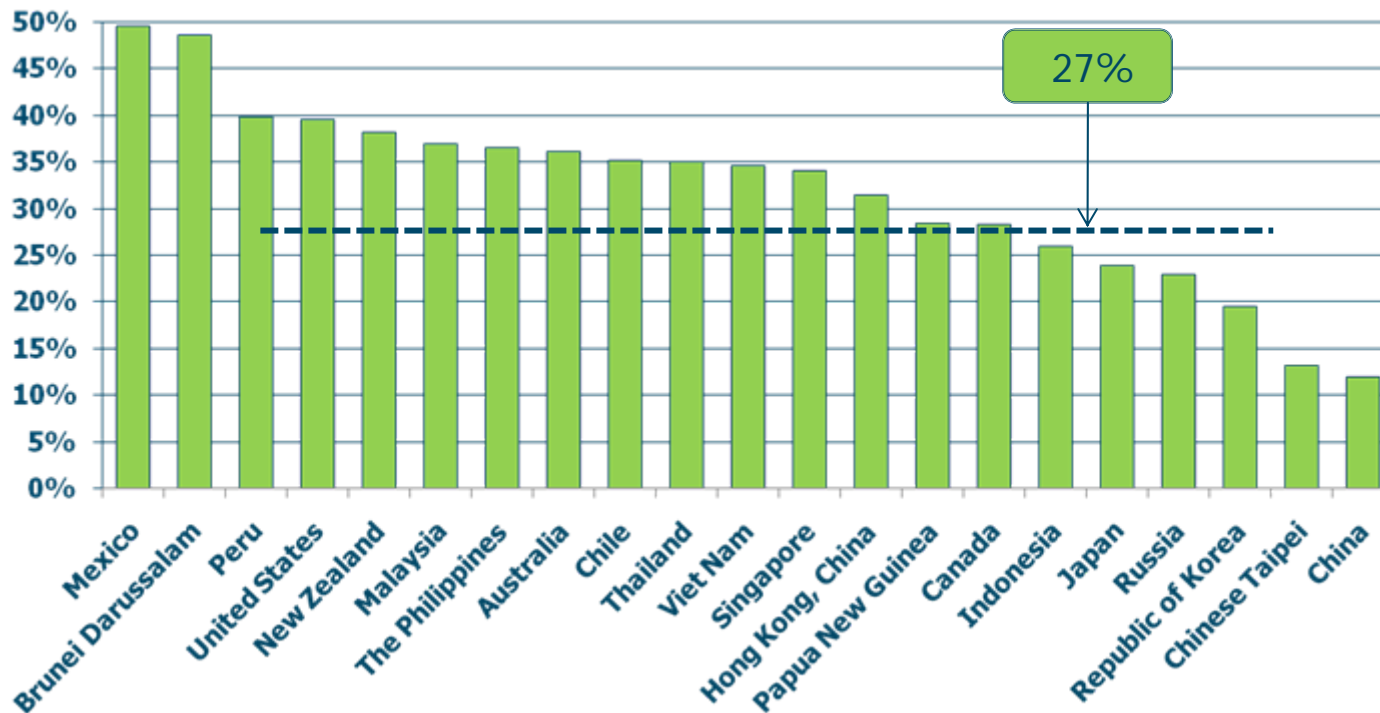



SMART TRANSPORT: ENERGY-EFFICIENT URBAN TRANSPORT NETWORK

Reducing the time, energy, and carbon emissions associated with moving people from one place to another

Deliverables

1. Website on ESCI Knowledge Sharing Platform (KSP) and folder with examples of energy-efficient urban transport strategies in APEC
2. Analysis of best practices for bus rapid transit and transit oriented development, based on examples

Coordinator (United States):

1. Develops template for sharing information on energy-efficient urban transport strategies, including estimate of savings in cost, energy use, and carbon emissions
2. Develops a system for sharing and posting the information and selecting best practices.

Participants

Contribute examples of energy-efficient urban transport strategies in their economies, utilizing the standard template and providing additional detailed documentation for estimated savings.

Example Systems

1. Transit-oriented development
2. Bus rapid transit
3. Light rail
4. Bike paths and walkways
5. Congestion management



SMART TRANSPORT: ENERGY-EFFICIENT FREIGHT TRANSPORT NETWORK

Reducing the cost, energy use and the carbon footprint of transporting goods among customers or between factory and market

Deliverables

1. Website on ESCI Knowledge Sharing Platform (KSP) and folder with examples of energy-efficient freight strategies across APEC
2. Analysis of best practices for freight logistics and intermodal freight for the region, based on examples

Coordinator

1. Develop template for sharing information on energy-efficient freight strategies, including estimate of savings in cost, energy use and carbon emissions.
2. Develop a system for sharing and posting the information and selecting best practices.

Participants

Contribute examples of energy-efficient freight strategies in their respective economies, utilizing the standard template and providing additional detailed documentation for estimated savings.

Example Methods

1. Logistical strategies to raise the load factors of transport vehicles
2. Intermodal strategies to shift freight from trucks to railroads, ships and barges



SMART TRANSPORT: ELECTROMOBILITY SURVEY AND ROADMAP

Establishing networks of charging stations for electric vehicles, which use less energy and emit less carbon while reducing reliance on foreign oil

Deliverables

1. Website on ESCI Knowledge Sharing Platform (KSP) with compendium of strategies for electric vehicle charging infrastructure
2. Assessment of best practices for boosting electric vehicle markets through infrastructure expansion

Coordinator (Canada)

1. Develops template for sharing information on strategies for expansion of electric vehicle charging infrastructure.
2. Develops a system for posting the information and selecting best practices.

Participants

Contribute examples of electric vehicle charging infrastructure and assessments of how the infrastructure will promote expansion of electric vehicle markets.



SMART TRANSPORT: ELECTRIC VEHICLE DEMONSTRATIONS

Demonstrating advanced EV technologies that increase driving range, reduce charging times, enhance performance, improve energy efficiency

Deliverables

1. Consistent database of information on electric vehicle technologies available within APEC

Coordinator (Japan)

1. Develops a template for sharing information on electric vehicle demonstration projects, including an estimate of improvements in range, charging time, performance and efficiency.
2. Develops a system for posting the information and selecting best practices.

Participants

Document electric vehicle demonstration projects in their economies, utilizing the standard template and providing additional detailed documentation for estimated improvements in vehicle driving range, charging time, performance, fuel efficiency.

SMART BUILDINGS



Low-Energy Buildings Network



Materials Testing and Rating Center



Cool Roof Demonstrations



Low Energy Window Demonstrations



Smart Buildings

SMART BUILDINGS

- Buildings account for 33% of energy use in APEC region.
- Buildings account for 15% of carbon emissions worldwide.
- Under current policies, IEA predicts energy consumption in buildings will grow 1% annually, account for 33% of total energy consumption in 2035.

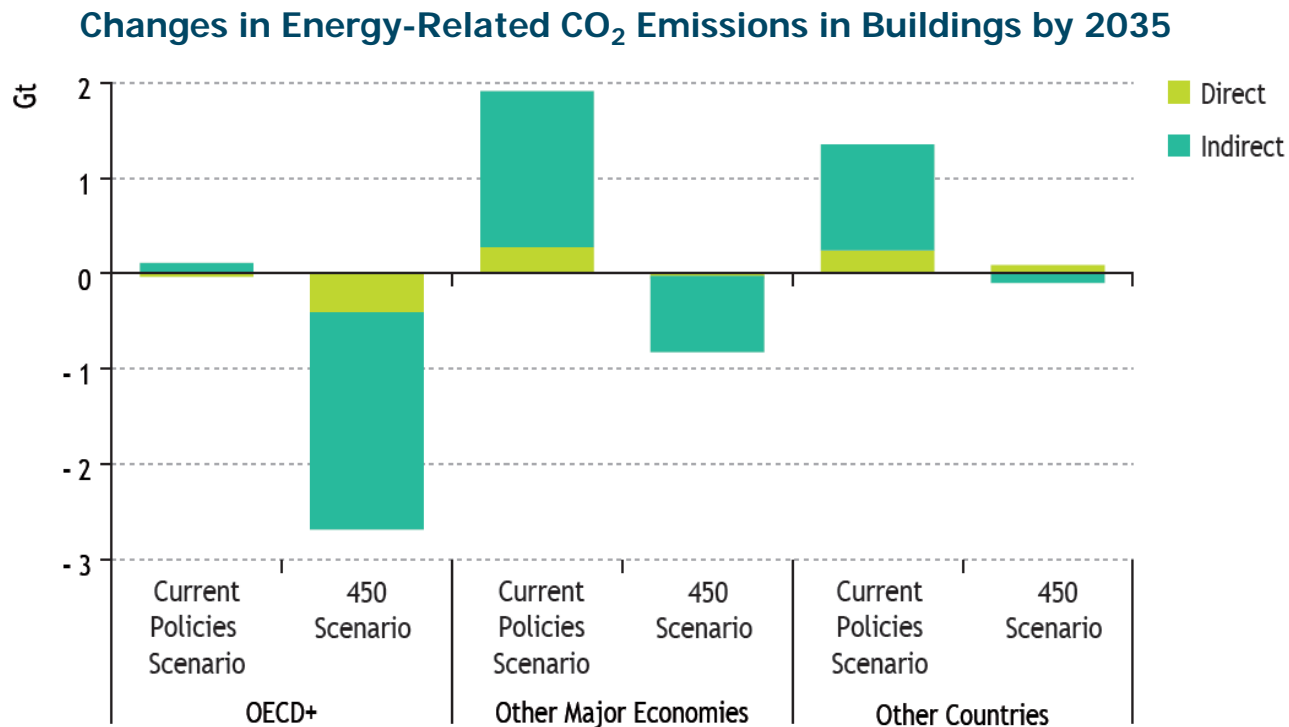

Source: Energy Information Agency, *World Energy Outlook 2010*



SMART BUILDINGS: LOW ENERGY BUILDINGS NETWORK

Establishing a registry of NEW buildings using at least 50% less energy and RETROFITTED buildings using at least 25% less energy

Deliverables

1. Website on ESCI Knowledge Sharing Platform (KSP) and folder with examples of low-energy buildings from every APEC economy
2. Analysis of best practices for low-energy building design across the APEC region, based on examples

Coordinator (Singapore)

1. Develop a template for sharing information on low-energy buildings, including key design features and estimated savings in cost, energy use and carbon emissions.
2. Develop a system for sharing and posting the information and selecting best practices.

Participants

Contribute one or more examples of low-energy buildings in their economies, utilizing the standard template and providing additional detailed documentation for estimated savings.

Example Technologies:

1. Energy-efficient walls, roofs, windows, heating, cooling, and ventilation systems
2. Solar hot water heating
3. Solar cells for electricity generation



SMART BUILDINGS: MATERIALS TESTING AND RATING CENTER

Providing accurate and consistent performance data for buying energy-efficient building components from anywhere in APEC

Deliverables

1. Building materials testing and rating center for use by APEC economies
2. Compendium of data on the performance of energy-efficient building materials available within APEC

Coordinator (Thailand):

1. Works with private industry, host economy policymakers, and investment organizations to establish a building materials testing and rating center.

Participants

Use the testing and rating center to certify the performance of energy-efficient building materials that are manufactured in their economies, thus promoting export markets for these materials.

SMART BUILDINGS: COOL ROOF DEMONSTRATIONS

Encouraging cost-effective use of cool roofs in new and existing buildings throughout the APEC region

Deliverables

1. Consistent database of information on cool roof technologies available in APEC
2. Possible demonstration of other energy-efficient advanced building envelope technologies such as
 - A. Advanced low-energy windows
 - B. Radiant barriers
 - C. Reflective wall coatings
 - D. Window films
 - E. Shading devices
 - F. Other strategies to reduce heat gains

Coordinator (United States)

1. Develop a template for sharing information on cool roof demonstration projects, including estimate of savings in cost, energy use and carbon emissions.
2. Develop a system for sharing and posting the information and selecting best practices.

Participants

Document one or more cool roof demonstration projects in their respective economies, utilizing the standard template and providing additional detailed documentation for estimated savings.

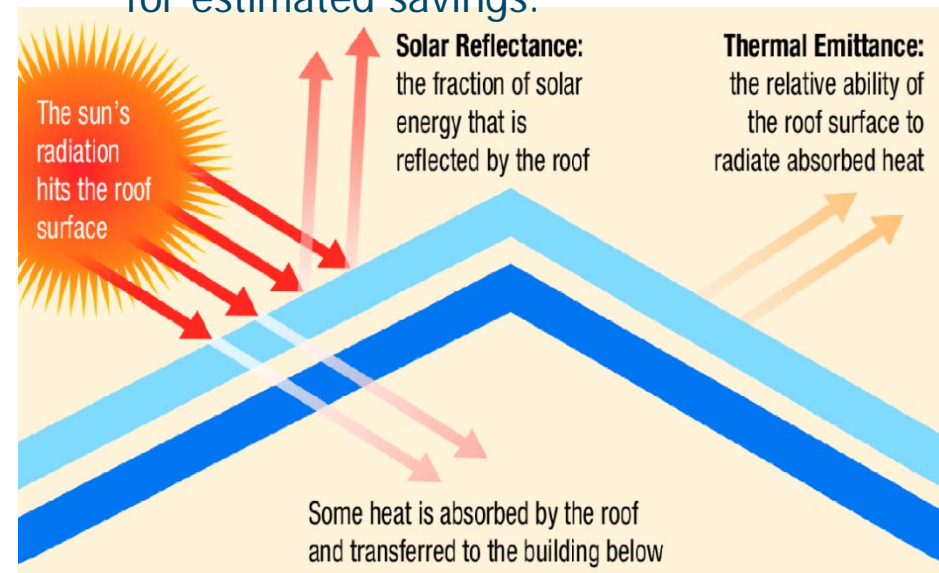

SMART BUILDINGS: LOW ENERGY WINDOW DEMONSTRATIONS

Conducting a demonstration projects to document cost savings from low energy windows in a range of building types and climates

Deliverables

1. Consistent database of information on window technologies available in APEC

Coordinator (United States)

1. Develop a template for sharing information on window demonstration projects, including estimated cost, energy use and carbon emissions.
2. Develop a system for sharing and posting the information and selecting best practices

Participants

Document one or more advanced window demonstration projects, utilizing the standard template and providing additional detailed documentation for estimated savings.

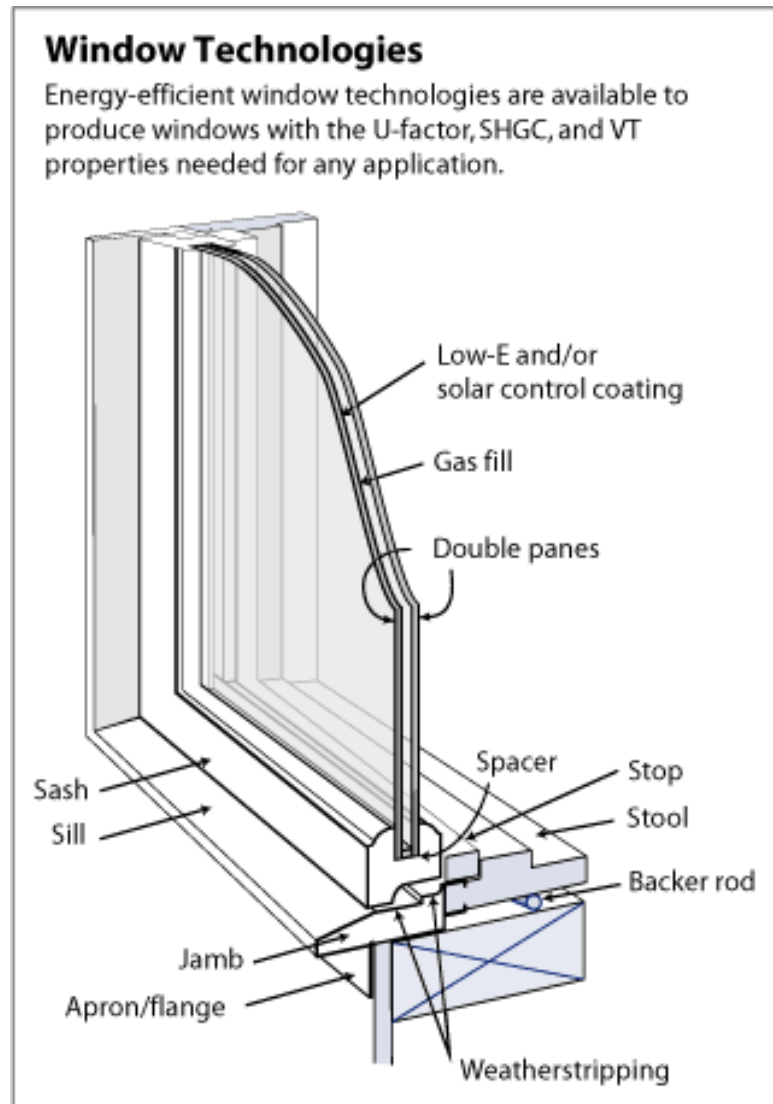

SMART GRIDS



**Interoperability
Survey And Road Map**



**Smart Grid Test
Bed Network**



Smart Grids

SMART GRIDS

- Increase energy efficiency by enabling demand response.
- Lower carbon emissions by reducing the need for as much production of electricity.
- Speed deployment of renewable energy by easing integration into the power grid.

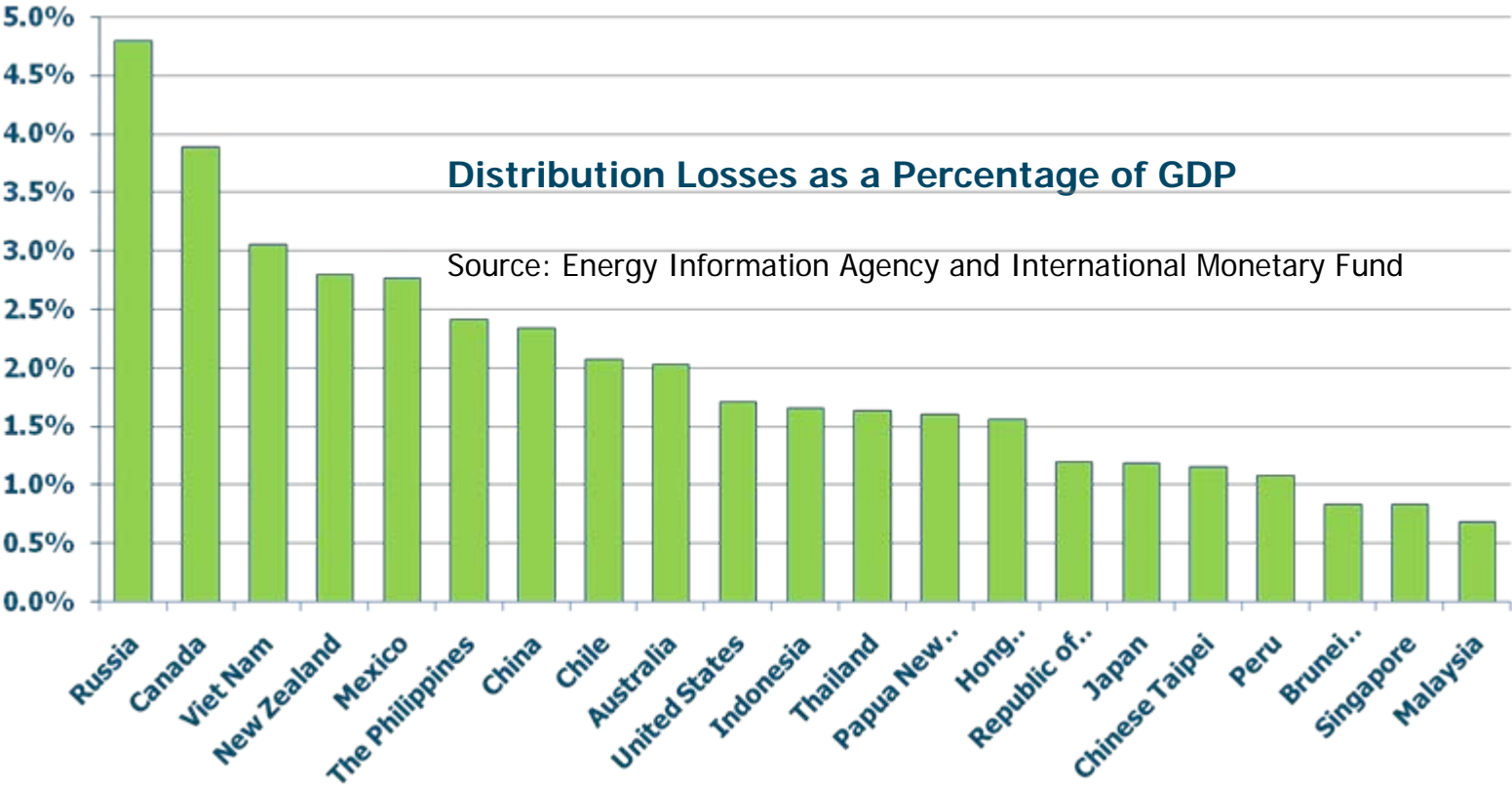



SMART GRIDS: INTEROPERABILITY SURVEY AND ROAD MAP

Collecting information on how to get the greatest boost to efficiency and renewables from smart grids and make them interoperable

Deliverables

1. Website on ESCI Knowledge Sharing Platform (KSP) with compendium of information on
 - A. Strategies for using smart grids to enhance energy efficiency and renewable energy use
 - B. Interoperability standards for smart grids in various economies
 - C. Practical ways to promote interoperability across neighboring smart power grids
2. Vision paper on interoperability standards to facilitate trade in smart grid technologies and electricity

Coordinator (United States)

1. Develop a template for sharing information on
 - A. The potential of smart grids to enhance energy efficiency and renewable energy use
 - B. Smart grid interoperability standards
2. Develop a system for posting the information and selecting best practices

Participants

Contribute detailed technical specifications for interoperability of smart grid technologies in their economies, as well as information on strategies for using smart grid technologies to promote efficient energy use in buildings and industry and to boost the share of renewable electricity.

SMART GRIDS: SMART GRID TEST BED NETWORK

Deliverables

1. A growing body of knowledge on smart grid technologies available within APEC.
2. Increased access to test beds by all APEC economies.

Coordinator (Korea)

1. Develops a template for sharing information on developing and demonstrating smart grid technologies.
2. Coordinates between test beds contributed by participants.

Participants

Contribute a test bed for smart grid technologies that all APEC economies can use, if available.



SMART JOBS



**Energy Efficiency
Training Curricula**



**Energy Efficiency
School Curricula**



**Sister Schools
Program**



Smart Jobs



SMART JOBS

The smart jobs initiative will create opportunities to train the workforce needed for energy smart communities to help save energy, reduce carbon emissions, and lower energy bills.

Smart Jobs for Smart Transport:

- Developing engineering curricula for advanced electric drive vehicles.
- Planning communities to reduce transport energy requirements.
- Driving and maintaining cars to boost fuel efficiency.

Smart Jobs for Smart Buildings:

- Designing energy-efficient building systems
- Conducting energy audits.
- Operating and maintaining building energy systems
- Living in an energy-efficient fashion.

Smart Jobs for Smart Grids:

- Designing, building and operating advanced smart power grids.



SMART JOBS: ENERGY EFFICIENCY TRAINING CURRICULA

Establishing a registry of energy efficiency training curricula that can be shared among APEC economies

Deliverables

1. Website on ESCI Knowledge Sharing Platform (KSP) with compendium of training materials and assessment of best practices for training

Coordinators (United States and Canada)

1. Develop a system for sharing information on training curricula for energy retrofits and efficient equipment installation.
2. Develop a system for posting the information and selecting best practices.

Participants

1. Contribute examples of low-energy buildings, utilizing the standard template and providing additional detailed documentation for estimated savings.
2. Translate materials into English for wider consideration throughout APEC.

Example Target Professions:

1. Energy efficiency auditors
2. Installers of equipment for energy efficiency retrofits
3. Certifiers of building compliance with energy efficiency standards



SMART JOBS: ENERGY EFFICIENCY SCHOOL CURRICULA

Establishing a registry of elementary and secondary school energy efficiency curricula that can be shared among APEC economies

Deliverables

1. Website on ESCI Knowledge Sharing Platform (KSP) with compendium of energy efficiency curricula and assessment of best practices

Coordinator (United States)

1. Develops a system for sharing information on elementary, middle school, high school, and university-level curricula on energy efficiency.
2. Develops a system for posting the information and selecting best practices.

Participants

1. Contribute examples of energy efficiency curricula, complete with texts and course materials.
2. Contribute staff or financial resources to assess best practices.
3. Translate the examples or key portions into English for wider consideration throughout APEC.



SMART JOBS: SISTER SCHOOLS PROGRAM

Building upon the energy efficiency curricula to establish sister schools for elementary and secondary students within the APEC region

Deliverable

1. Pairings of sister schools in APEC economies to share information on energy efficiency.

Coordinators (Japan and United States)

1. Develop a system for pairing schools in APEC economies that may wish to form a sister school relationship for sharing information on energy efficiency techniques and educational methods.
2. Provide lessons that the sister schools can use and then have students compare results.

Participants

Volunteer schools in their economies that wish to become sister schools.

CROSS-CUTTING ESCI ACTIVITIES



**Low Carbon
Model Towns**



**Knowledge
Sharing Platform**



LOW CARBON MODEL TOWNS (LCMT)

Combining energy-efficient buildings, transport, and power grids to create communities that affordably reduce energy use and carbon emissions while creating jobs

Deliverables

1. Survey of LCMTs in APEC
2. Website on ESCI Knowledge Sharing Platform, folder describing how smart transport, smart buildings and smart grids work together in LCMTs to reduce carbon emissions.
3. Feasibility studies to encourage creation of low-carbon communities in urban development plans.
4. Recommendations for measures that can be taken to reduce carbon emissions in all APEC communities.

Coordinators (Japan and China)

1. Develop a template for sharing information on LCMTs, including estimate of savings reductions in cost, energy use and carbon emissions).
2. Develop a system for sharing and posting information, highlighting best practices.
3. Analyze LCMTs selected in survey and provide recommendations for specific measures that can be taken to reduce carbon emissions.

Participants

1. Contribute examples of LCMTs in their economies, utilizing the standard template.
2. Provide additional detailed documentation for estimated savings related to smart transport, smart buildings, and smart grids.



KNOWLEDGE SHARING PLATFORM (KSP)

Gathering data and information collected by ESCI projects and presenting them in a web-based knowledge management center

Deliverables

1. Website with data on all ESCI projects

Coordinators (Chinese Taipei and United States)

1. Develop a web-based knowledge management center that will host and share each of the ESCI projects and related data.
2. Ensure that information and information gathering practices are done in a uniform and consistent way.
3. Work with project coordinators to obtain data in a timely and thorough manner.

Participants

Contribute data and information to the KSP through its participation in the various ESCI projects.